

SARAVEL PACKAGED AIR-COOLED LIQUID CHILLER

**10 TO 100 TONS
(35 TO 350 kW)**

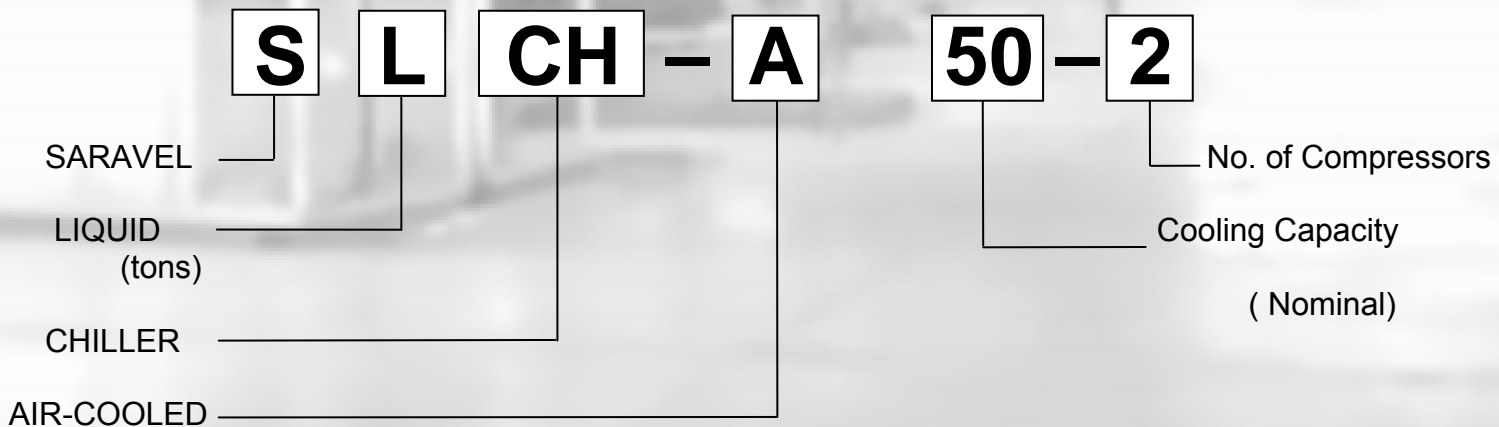

Introduction	3
Specifications	4
Examples	6
Physical Data	8
Rating Tables	10
Correction Factors	14
Sound Rating	15
Pressure Drop Curves	16
Dimensions	17
Installation Recommendation	18

NOMENCLATURE

Copyright © by SARAVEL Corp. 2003

All rights reserved. This catalog may not be reproduced in any form or by any means without the prior permission of Saravel Corp.

SARAVEL



INTRODUCTION

Saravel Packaged Air-Cooled Liquid Chillers offer innovative solutions to the challenges facing today's users and installers of air conditioning systems. Units are medium and high evaporating temperature range **30 to 54°F (-1 to 12°C)** and are available in 16 models in the range of **10 to 100 tons** (1 ton of cooling is 12000 Btu/hr) (or **35 to 350 kW**) for air conditioning and refrigeration applications, for halocarbon refrigerants as **R22, R134a or R407C**. (The units more than 100 tons (350 kW) are also could be built.)
(For more information please consult Saravel Corp.)

+ All components in SARAVEL Liquid Chillers are selected of reliable and recognized international brand names or designed and constructed and checked under the standard of the air-conditioning and refrigeration industry.

The units are manufactured under Saravel's own Quality Assurance System and also Saravel Standard Engineering Specification (SES).

+ For any other special or exceptional applications please consult **Saravel Corp.**

Combining modern manufacturing methods, stringent quality, assurance checks and proven components, ensures that units deliver ultimate performance. The ease of installation and minimum maintenance makes Saravel Air-Cooled Liquid Chillers ideal for year round applications in multistory office buildings, hotels, schools, industrial facilities and residential applications.

For industrial special purposes or exceptional types, customary built units can also be designed and constructed.



DEVICE	Condenser Coils						Compressor						Fans			
	Fin Type		Fin Material		Rows		Thermal Overload relays	Crank case Heater	Copper Vibration Absorber	Muffler (noise absorber)	High Pressure Cut-Out	Low Pressure Cut-Out	Oil Pressure Cut-Out	Centrifugal	Motor Speed Control	Motor Thermal Protection Device
	10 FPI	8 12 14 16 FPI	Al	Cu	3	4 or more										
STANDARD	☀		☀		☀		☀	☀	☀		☀	☀	☀			☀
OPTIONAL		☀		☀		☀				☀				☀	☀	

DEVICE	Receiver	Economizer (Heat Exchanger)	CaseWork	Valves and Filters				
				Expansion Valve	Filter Drier	Suction Filter	Service Valve	Charging Valve
STANDARD			☀	☀	☀	☀	☀	☀
OPTIONAL	☀	☀						

DEVICE	Controls																
	High Pressure Switch	Head Pressure Control Valve	Solonoid Valve	Needle Valve (Shredder)	Safety Valve	Hot Gas Bypass	Suction Gas Cooling	Suction Gas Accumulator	Oil Separator	Sight Glass			Thermostat	Part-Winding	Flow Switch	Electronic Logic Relay Control (LOGO)	Automatic Electronic Control Board (PLC)
										Liquid	Suction Line	Oil					
STANDARD	☀		☀		☀					☀		☀	☀		☀		
OPTIONAL		☀		☀		☀	☀	☀	☀		☀			☀		☀	



SPECIFICATIONS

4

Reliability and proven performance are incorporated into the following design features:

COMPRESSORS

The compressors used in Saravel Air-Cooled Liquid Chiller are made by famous international companies that has many experiences in manufacturing long life and efficient compressors.

They are designed to run on 380 volt, 3 phase, 50 cycle electricity.

The extremely compact, rugged and featuring low noise and vibration level compressors which incorporate many engineering features, was the reason for Saravel to choose them as the best.

The compressors associated with the new Semi-Hermetic technology are highly resistant to wear and tear.

Conformable, precise-casting pistons eliminate piston slap while maintaining a closer piston fit under all operating conditions while holding groove and ring wear to a minimum. Lubricating oil for the running gear is supplied by an oil centrifuge which lubricates the internal moving components through an internally challenged and piped lubricating system.

EVAPORATORS

The direct expansion cooler designed for highest efficiency features, the refrigerant flows in the tubes, and a series of baffles direct water over the refrigerant tubes.

The tube bundle is removable. The evaporator and low temperature lines are completely protected with closed-cell foam rubber fire retardant insulation for thermal insulating, condensation prevention, and vapor seal.

The Evaporators are designed and constructed according to the ASME-Section VIII Unfired Pressure Vessel Code and the standards of Tubular Exchanger Manufacturers Association (TEMA).

FANS

All fans are recessed below top of unit and have externally (or internally) driven electrical motor.

The high efficiency and low noise fans used in units are covered with fan guards, which are easily removable for cleaning and services.

+ Optionally all the motors are fitted with a thermal protection device of the self-resetting type, to protect the motor from dangerous overheating.

+ The motors can be speed controlled by variation of the supply voltage with either electronic controllers or transformers (optional).

+ **In other applications, units with centrifugal fans can also be fabricated.**

CONDENSERS

Condenser coils consist of 5/8" OD (Outer Diameter) 3 rows deep copper tubes with fin spacing of 10 FPI (Fin per inch). (In exceptional cases they can also built 8, 12, 14 or 16 FPI.)

Additionally, coils contain an integral liquid sub-cooling section to enhance performance and maintain liquid quality.

Tube pattern includes staggered arrangement, providing economical selection for specific duty and application ranges. Standard coils are designed with 5/8" copper tubes

+ Fin materials include aluminum and copper.

+ Coils are designed and tested for 350 psig (24 bar) pressure and evacuated and backfilled with 15 psig (1 bar) nitrogen gas prior to shipment.

+ Headers are of heavy wall copper or carbon steel.

+ All connections are of the sweat type suitable for brazing.

EXPANSION VALVE

Quick-response, non-adjustable and factory set expansion valves, have been used in the units.

RECEIVERS

Units optionally include a receiver for condensed liquid leaving the condenser.

BUILT-IN HEAT EXCHANGER

Optionally, units can be furnished with built-in heat exchangers (inside the receiver), minimizing the possibility of liquid slugging and providing additional sub-cooling.

CASEWORK

All casing are constructed of heavy gage galvanized steel sheet panels which are electro statically powder painted and subsequently oven cured at 180°C to provide an even, flexible and durable gray gloss finish as well as excellent corrosion protection. Fan panels have long smooth radius outlet orifices to assure high efficiency and low noise level. The body structure are made of heavy gage galvanized steel and for larger units, structural steel profiles provide maximum rigidity. Units are provided with lifting eyes and footpads for ease of transport and installation.



SPECIFICATIONS

5

CONTROLS

Air-Cooled Liquid Chillers utilize a control panel designed for automatic operation and phase control for insuring the safety, efficiency and cost effective operation of the unit, while providing sequencing control for the fans to obtain a satisfactory performance for different situations.

- + **High pressure (HP) switch** actuates the fans of the condenser coil separately, for increasing or decreasing the efficient condensing surface, which in turn, decreases or increases the head pressure.
- + A **Head Pressure Control Valve (Optional)** works to maintain necessary head pressure under low ambient conditions (When condensing temperature falls below 95°F (35°C)). In these cases when head pressure fall exceeds a pre-set minimum, the head pressure control valve bypasses part of hot gases to prevent over sub-cooling of the liquid and more reduction in head pressure, which can cause inefficient working conditions.

By these control systems, the head pressure can always be maintained at an acceptable level.

- + In order to respond to various load conditions, Partial unloading and capacity control is obtained by a **solenoid valve**, which connects suction line to discharge line of each cylinder, over 25 tons compressor types.
- + **Part-winding** is optionally applicable for compressors over 40 tons (140 kW). In other cases, the compressor starts with direct starting method.
- + In order to protect the compressor, units feature thermal overload relays, avoiding undesirable work conditions.
- + The safety controls include high and low pressure cut-outs, oil pressure safety cut-out, motor overload protection and flow switch.
- + Also fitted is a electronic logic relay control with an adjustable (five minutes) 'Delay On' and compressor short cycle, single phase and locked rotor prevention function. The 'Delay On' timer prevents excessive starting currents on multiple installations.
If required, different start times may be set.(this only delays restarting the units on powering up, e.g. after a power cut).
- + Each unit circuit is equipped with a service liquid shut-off valve for manual pump down operation, safety valve, and a charging valve.

- + Saravel also offers PLC, an optional digital electronic control system. This system digitally monitors and controls the operation of single and multiple-compressor chillers. The control panel features a complete display of chilled and condenser water temperatures and all safety trips, alarms and control set points. An added feature is remote diagnostics capability, which enables the operator to change set points, start/stop the chiller via a modem. With network connection adaptability, this system can easily be integrated within Building Management Systems (BMS).
- + A number of further protection devices are fitted as standard – for example, HP/LP switch (manual/auto) and electrical protection of condenser fan motors against overload and short circuits.
- + *All control components are located in an easily accessible, separate enclosure at the front of the unit.*

OTHER FEATURES

- + All compressors and liquid receivers, feature service valves which allow quick and easy unit maintenance.
- + Systems are supplied complete with filter/drier and sight glass.
- + Pressure controls are fitted with flexible hoses with machined fitting complying with the latest refrigeration practices.
- + A crankcase heater with sight glass is standard on all models.
- + Resetting of all controls may be accomplished by turning the thermostat to the OFF position and back to AUTOMATIC.



EXAMPLES

Example 1: Packaged Air-Cooled Liquid Chiller Selection

Given:
 Required Capacity 400 kBtu/hr
 Required Chilled Leaving water Temp 45° F
 Ambient Air Temperature 105° F
 Altitude of Installation 1500m
 Refrigerant R22

Find:
 (a) Select Suitable Packaged Air-Cooled Liquid Chiller.
 (b) Required water flow for this capacity (GPM)
 (c) Water pressure drop in passing through chiller

Solution:
 It is possible to choose either a two-compressor or a single-compressor model. Suppose it has been decided to have a two-compressor model. Selection procedure for two-compressor models or single-compressor ones are precisely the same.

- + Altitude correction factor for 1500m obtained from table C.1 On page 14 is 0.97. So C1 = 0.97
 About the other correction factors because there are no limitation in assumptions we take them as standard situations as follows:
- + Fin Material: Al (standard): (from table C2): C2 = 1
- + Fin Arrangement: 10 FPI (Fin Per Inch)(standard): (from table C3): C3 = 1
- + Refrigerant Correction Factor: (for R22) C4 = C5 = 1
 (For more explanation about correction factors please refer to page 14.)

$$\text{Corrected amount for using the tables} = \frac{400 \text{ kBtu/hr}}{C1 \times C2 \times C3 \times C4 \times C5} = 412 \text{ kBtu/hr}$$

412 kBtu/hr / 12 Ton/kBtu/hr = **34.3 Tons**
 Nearest matched nominal size : 40 tons }
 Tons of cooling required
 2 comp. } **SLCH 40-2**

SLCH 40-2 }
 Air Temperature (Ambient) : 105 °F } Table 3
 Chilled Leaving Water Temp. : 45 °F }

From table 3:
 Cooling Capacity = 28.2 Tons
 28.2 < 34.3 (required)

So **SLCH 40-2** Is **NOT** a suitable selection.

So the next unit is to be checked.

Next choice : **SLCH 50-2** }
 Air Temperature (Ambient) : 105 °F } Table 3
 Chilled Leaving Water Temp. : 45 °F }

From table 3 :
 Cooling Capacity = 35.2 Tons
 35.2 > 34.3 (required)

So **SLCH 50-2** Is a suitable Selection.

Reading other related ratings from table 3:
Cooling Capacity : 35.2 Tons
Compressors Input Power : 36.6 kW
Required Chilled Water GPM : 85 GPM
Chiller water pressure drop : 10.8 ft. of water



EXAMPLES

Example 2:

Packaged Air-Cooled Liquid Chiller Selection

Given:

- Required Capacity 550 kBtu/hr
- Required Chilled Leaving water Temp. 44° F
- Ambient Air Temperature 100° F
- Altitude of Installation 2500m
- Refrigerant R134a
- Condenser Fin Arrangement (Fin Per Inch) 14 FPI
- Fin Material Cu

Find:

- (a) Select Suitable Air-Cooled Liquid Chiller.
- (b) Required water flow for this capacity (GPM)
- (c) Water pressure drop in passing through chiller

Solution:

- + Altitude correction factor for 2500m obtained from table C1 is 0.94. (C1=0.94)
- + Cu Fin Material Correction Factor obtained from table C2 is 1.01 (C2 = 1.01)
- + 14 FPI Correction Factor obtained from table C3 is 1.011. (C3 = 1.011)
- + Refrigerant correction factor for R134a from table C4 is 0.962 (C4 = 0.962) (This amount has been obtained by assuming a SLCH 60-2 as the final selection and will be revised later.)
- + Refrigerant correction factor for R134a from table C5 is 0.982. (By Interpolation) (C5 = 0.982)

$$\text{Corrected amount for using the tables} = \frac{550 \text{ kBtu/hr}}{C1 \times C2 \times C3 \times C4 \times C5} = 607 \text{ kBtu/hr}$$

$$607 \text{ kBtu/hr} / 12 \text{ Ton/kBtu/hr} = \mathbf{51 \text{ Tons}}$$

Tons of cooling Required

Nearest matched nominal size is 60 tons (SLCH 60-2):

SLCH 60-2	}	Table 3
Air Temperature (Ambient) : 100 °F		
Chilled Leaving Water Temp. : 44 °F		

From table 3:
By Interpolation for 100°F (100=(105+95)/2) :

$$\text{Cooling Capacity} = (40.7+43.5)/2 = 42.1 \text{ Tons}$$

$$42.1 < 51 \text{ Tons (required)}$$

So **SLCH 60-2** Is **NOT** a suitable Selection.

So the next unit is to be checked
Nearest matched nominal size (more than 60):
80 tons (SLCH 80-2)

If SLCH 80-2 is to be selected then the amount of C4 (obtained for SLCH 60-2) should be revised.
The other correction factors remain unchanged.
So from table C4 for SLCH 80-2: (C4 = 0.807)
Then recalculating the corrected capacity:

$$\text{Corrected amount for using the tables} = \frac{550 \text{ kBtu/hr}}{C1 \times C2 \times C3 \times C4 \times C5} = 723 \text{ kBtu/hr}$$

$$723 \text{ kBtu/hr} / 12 \text{ Ton/kBtu/hr} = \mathbf{60.3 \text{ Tons}}$$

Tons of cooling Required

SLCH 80-2	}	Table 3
Air Temperature (Ambient) : 100 °F		
Chilled Leaving Water Temp. : 44 °F		

From table 3 :
By Interpolation for 100°F (100=(105+95)/2) :

$$\text{Cooling Capacity} = (59.4+63.6)/2 = 61.5 \text{ Tons}$$

$$61.5 > 60.3 \text{ (required)}$$

So **SLCH 80-2** Is a suitable Selection.

Reading other related ratings from table 3 using interpolation:

Cooling Capacity	: 61.5 Tons
Compressors Input Power	: 63.4 kW
Required Chilled Water GPM	: 148 GPM
Chiller water pressure drop	: 20 ft. of water



UNIT CHARACTERISTICS

Table 1 – Physical Data

Model		10-1	15-1	20-1	25-1	30-1	40-1	50-1	60-1
Compressor (Semi Hermetic)	No. of Compressors	1	1	1	1	1	1	1	1
	No. of Cylinders (Each Comp.)	3	3	4	4	4	6	8	8
	Motor HP (Each Comp.)	10	15	20	25	30	40	50	60
	Sound Press. Lev. At 1 m (dB)	63	70	70	71	80	80	77	77
	Capacity Control Steps %	100	100	50 100	50 100	50 100	33 - 66 100	50 - 75 100	50 - 75 100
Evaporator (Water Cooled Shell & Tube)	No. of Evaporators	1	1	1	1	1	1	1	1
	Shell Outer Diameter (inch)	12	12	14	12	12	12	12	14
	Tube Length (mm)	2000	2000	2000	2500	2500	3000	3000	3000
	Water Volume (Lit.)	90	90	109	113	113	137	137	165
	Water In & Out Flange (in.)	2.5	2.5	2.5	2.5	3	3	3	3
Condenser (Air Cooled Coil)	Model of Used Condenser	SAC-250	SAC-250	SAC-350	SAC-450	SAC-450	SAC-550	SAC-700	SAC-850
	No. of Coils	2	2	2	2	2	2	4	4
	No. of Fans (Axial)	2	2	4	6	6	6	8	8
	Tube Finned Length (mm)	1940	1940	1940	2440	2440	2940	1940	2440
	Coil Rows	3	3	3	3	3	3	3	3
	Fin Per Inch	10	10	10	10	10	10	10	10
	Fin Type	Al	Al	Al	Al	Al	Al	Al	Al
Operating Charges	Oil (liters)	3.8	3.8	3.6	4	4	7.4	7.7	7.7
	Refrigerant R-22 (kg)	18	22	30	40	48	70	90	124
Operating Weight	Total Operating Weight (kg)	1700	1750	1950	2100	2300	2500	3300	3750

Table 2 – Electrical Data

Model		10-1	15-1	20-1	25-1	30-1	40-1	50-1	60-1
Compressor	No. of Compressors	1	1	1	1	1	1	1	1
	Max. Power Input (kW)	12	16	18	23	28	43	51	61
	Max. Operating Current (Amps)	25	31	31	40	48	72	92	107
	Locked Rotor (Amps)	96	129	160	192	218	347	444	544
System	Max. Operating Current (Amps)	30	36	40	54	62	86	110	125
	Max. Starting Current (Amps)	116	139	185	221	247	376	478	578
Wire Sizing Required (Amps)		37	45	50	67	77	107	138	157



UNIT CHARACTERISTICS

Table 1 – Physical Data

Model		15-2	20-2	30-2	40-2	50-2	60-2	80-2	100-2
Compressor (Semi Hermetic)	No. of Compressors	2	2	2	2	2	2	2	2
	No. of Cylinders (Each Comp.)	2	3	3	4	4	4	6	8
	Motor HP (Each Comp.)	7.5	10	15	20	25	30	40	50
	Sound Press. Lev. At 1 m (dB)	61	66	73	73	74	83	83	80
	Capacity Control Steps %	50 100	50 100	50 100	25 - 50 75 - 100	25 - 50 75 - 100	25 - 50 75 - 100	17-33-50 67-83-100	25-38-50 75-88-100
Evaporator (Water Cooled Shell & Tube)	No. of Evaporators	1	1	1	1	1	1	1	1
	Shell Outer Diameter (inch)	14	14	12	12	14	14	16	16
	Tube Length (mm)	2000	2000	2550	3000	3000	3000	3000	3000
	Water Volume (Lit.)	109	109	117	137	165	165	224	215
	Water In & Out Flange (in.)	2.5	2.5	3	3	3	3	4	4
Condenser (Air Cooled Coil)	Model of Used Condenser	SAC-250	SAC-350	SAC-450	SAC-550	SAC-700	SAC-850	SAC-1200	SAC-1200
	No. of Coils	2	2	2	2	4	4	4	4
	No. of Fans (Axial)	2	4	6	6	8	8	12	12
	Tube Finned Length (mm)	1940	1940	2440	2940	1940	2440	2940	2940
	Coil Rows	3	3	3	3	3	3	4	4
	Fin Per Inch	10	10	10	10	10	10	10	10
Operating Charges	Fin Type	Al	Al	Al	Al	Al	Al	Al	Al
	Oil (liters)	2x2.8	2x3.8	2x3.8	2x3.6	2x4	2x4	2x7.4	2x7.7
Operating Weight	Refrigerant R-22 (kg)	30	40	50	65	75	90	135	165
	Total Operating Weight (kg)	1900	2150	2450	2650	3400	3900	4550	4800

Table 2 – Electrical Data

Model		15-2	20-2	30-2	40-2	50-2	60-2	80-2	100-2
Compressor (Each)	No. of Compressors	2	2	2	2	2	2	2	2
	Max. Power Input (kW)	9	12	16	18	23	28	43	51
	Max. Operating Current (Amps)	18	25	31	31	40	48	72	92
	Locked Rotor (Amps)	78	96	129	160	192	218	347	444
System	Max. Operating Current (Amps)	41	59	77	75	99	114	171	211
	Max. Starting Current (Amps)	116	146	190	220	266	300	462	579
Wire Sizing Required (Amps)		51	74	96	94	123	142	214	264



UNIT RATINGS

Table 3 – Unit Ratings Table

Air Cooled Chiller	Chilled Leaving Water Temp. °F (°C)	Air Temperature Entering Condenser of Chiller (Ambient)																			
		85 °F (29 °C)				95 °F (35 °C)				105 °F (41 °C)				115 °F (46 °C)				125 °F (52 °C)			
		Cooling Capacity Tons (kW)	Comp. Input Power (KW)	Chilled Water GPM (m ³ /hr)	Chilled Water PD. ft. (m)	Cooling Capacity Tons (kW)	Comp. Input Power (KW)	Chilled Water GPM (m ³ /hr)	Chilled Water PD. ft. (m)	Cooling Capacity Tons (kW)	Comp. Input Power (KW)	Chilled Water GPM (m ³ /hr)	Chilled Water PD. ft. (m)	Cooling Capacity Tons (kW)	Comp. Input Power (KW)	Chilled Water GPM (m ³ /hr)	Chilled Water PD. ft. (m)	Cooling Capacity Tons (kW)	Comp. Input Power (KW)	Chilled Water GPM (m ³ /hr)	Chilled Water PD. ft. (m)
SLCH 10-1	42 (5.6)	9.7 (34.0)	7.5 (7.5)	23 (5.2)	0.8 (0.3)	9.0 (31.6)	8.2 (8.2)	22 (5.0)	0.8 (0.2)	8.3 (29.3)	8.8 (8.8)	20 (4.5)	0.6 (0.2)	7.7 (27.1)	9.4 (9.4)	19 (4.3)	0.6 (0.2)	7.0 (24.8)	9.9 (9.9)	17 (3.9)	0.5 (0.1)
	44 (6.7)	10.1 (35.4)	7.6 (7.6)	24 (5.5)	0.9 (0.3)	9.4 (33.0)	8.3 (8.3)	23 (5.2)	0.8 (0.3)	8.7 (30.6)	9.0 (9.0)	21 (4.8)	0.7 (0.2)	8.0 (28.1)	9.6 (9.6)	20 (4.5)	0.6 (0.2)	7.4 (26.0)	10.1 (10.1)	18 (4.1)	0.5 (0.2)
	45 (7.2)	10.3 (36.2)	7.6 (7.6)	25 (5.7)	1.0 (0.3)	9.6 (33.7)	8.3 (8.3)	23 (5.2)	0.8 (0.3)	8.9 (31.3)	9.0 (9.0)	21 (4.8)	0.7 (0.2)	8.2 (28.9)	9.6 (9.6)	20 (4.5)	0.6 (0.2)	7.5 (26.5)	10.2 (10.2)	18 (4.1)	0.5 (0.2)
	46 (7.8)	10.5 (36.9)	7.6 (7.6)	25 (5.7)	1.0 (0.3)	9.8 (34.4)	8.4 (8.4)	24 (5.5)	0.9 (0.3)	9.1 (31.8)	9.1 (9.1)	22 (5.0)	0.8 (0.2)	8.4 (29.4)	9.7 (9.7)	20 (4.5)	0.6 (0.2)	7.7 (27.1)	10.3 (10.3)	18 (4.1)	0.5 (0.2)
SLCH 15-1	42 (5.6)	12.4 (43.7)	10.2 (10.2)	30 (6.8)	1.5 (0.5)	11.7 (41.2)	11.1 (11.1)	28 (6.4)	1.3 (0.4)	11.0 (38.6)	11.9 (11.9)	26 (5.9)	1.1 (0.3)	10.2 (35.8)	12.7 (12.7)	24 (5.5)	1.0 (0.3)	9.5 (33.3)	13.5 (13.5)	23 (5.2)	0.9 (0.3)
	44 (6.7)	12.9 (45.4)	10.3 (10.3)	31 (7.0)	1.6 (0.5)	12.2 (42.8)	11.2 (11.2)	29 (6.6)	1.4 (0.4)	11.4 (40.2)	12.1 (12.1)	27 (6.1)	1.2 (0.4)	10.6 (37.3)	13.0 (13.0)	25 (5.7)	1.0 (0.3)	9.9 (34.7)	13.8 (13.8)	24 (5.5)	1.0 (0.3)
	45 (7.2)	13.2 (46.3)	10.4 (10.4)	32 (7.3)	1.7 (0.5)	12.4 (43.7)	11.3 (11.3)	30 (6.8)	1.5 (0.5)	11.7 (41.0)	12.2 (12.2)	28 (6.4)	1.3 (0.4)	10.8 (38.1)	13.1 (13.1)	26 (5.9)	1.1 (0.3)	10.1 (35.5)	13.9 (13.9)	24 (5.5)	1.0 (0.3)
	46 (7.8)	13.4 (47.2)	10.5 (10.5)	32 (7.3)	1.7 (0.5)	12.7 (44.5)	11.4 (11.4)	30 (6.8)	1.5 (0.5)	11.9 (41.8)	12.4 (12.4)	29 (6.6)	1.4 (0.4)	11.1 (38.9)	13.2 (13.2)	27 (6.1)	1.2 (0.4)	10.3 (36.2)	14.1 (14.1)	27 (6.1)	1.2 (0.4)
SLCH 15-2	42 (5.6)	13.3 (46.7)	11.5 (11.5)	32 (7.3)	1.7 (0.5)	12.6 (44.1)	12.4 (12.4)	30 (6.8)	1.5 (0.5)	11.7 (41.2)	13.3 (13.3)	28 (6.4)	1.3 (0.4)	10.9 (38.2)	14.2 (14.2)	26 (5.9)	1.1 (0.3)	10.0 (35.1)	14.9 (14.9)	24 (5.5)	1.0 (0.3)
	44 (6.7)	13.8 (48.6)	11.6 (11.6)	33 (7.5)	1.8 (0.5)	13.0 (45.8)	12.6 (12.6)	31 (7.0)	1.6 (0.5)	12.2 (42.9)	13.6 (13.6)	29 (6.6)	1.4 (0.4)	11.3 (39.7)	14.4 (14.4)	27 (6.1)	1.2 (0.4)	10.4 (36.6)	15.3 (15.3)	25 (5.7)	1.0 (0.3)
	45 (7.2)	14.1 (49.5)	11.7 (11.7)	33 (7.5)	1.8 (0.5)	13.3 (46.6)	12.7 (12.7)	32 (7.3)	1.7 (0.5)	12.4 (43.7)	13.7 (13.7)	30 (6.8)	1.5 (0.5)	11.5 (40.5)	14.6 (14.6)	28 (6.4)	1.3 (0.4)	10.6 (37.3)	15.4 (15.4)	25 (5.7)	1.0 (0.3)
	46 (7.8)	14.4 (50.5)	11.8 (11.8)	34 (7.7)	1.9 (0.6)	13.5 (47.5)	12.8 (12.8)	32 (7.3)	1.7 (0.5)	12.7 (44.5)	13.8 (13.8)	30 (6.8)	1.5 (0.5)	11.8 (41.3)	14.7 (14.7)	28 (6.4)	1.3 (0.4)	10.8 (38.0)	15.6 (15.6)	26 (5.9)	1.1 (0.3)
SLCH 20-1	42 (5.6)	15.3 (53.8)	11.5 (11.5)	37 (8.4)	2.3 (0.7)	14.4 (50.7)	12.6 (12.6)	35 (7.9)	2.1 (0.6)	13.5 (47.6)	13.7 (13.7)	32 (7.3)	1.7 (0.5)	12.7 (44.5)	14.7 (14.7)	30 (6.8)	1.5 (0.5)	11.8 (41.4)	15.6 (15.6)	28 (6.4)	1.3 (0.4)
	44 (6.7)	15.9 (55.9)	11.6 (11.6)	38 (8.6)	2.5 (0.7)	15.0 (52.6)	12.8 (12.8)	36 (8.2)	2.2 (0.7)	14.1 (49.4)	13.9 (13.9)	34 (7.7)	2.0 (0.6)	13.2 (46.3)	14.9 (14.9)	32 (7.3)	1.7 (0.5)	12.3 (43.1)	15.8 (15.8)	29 (6.6)	1.4 (0.4)
	45 (7.2)	16.2 (56.9)	11.6 (11.6)	39 (8.9)	2.6 (0.8)	15.3 (53.6)	12.9 (12.9)	37 (8.4)	2.3 (0.7)	14.3 (50.4)	14.0 (14.0)	34 (7.7)	2.0 (0.6)	13.4 (47.1)	15.0 (15.0)	32 (7.3)	1.7 (0.5)	12.5 (43.9)	16.0 (16.0)	30 (6.8)	1.5 (0.5)
	46 (7.8)	16.5 (58.0)	11.7 (11.7)	40 (9.1)	2.7 (0.8)	15.5 (54.7)	13.0 (13.0)	37 (8.4)	2.3 (0.7)	14.6 (51.3)	14.1 (14.1)	35 (7.9)	2.1 (0.6)	13.7 (48.1)	15.1 (15.1)	33 (7.5)	1.9 (0.6)	12.7 (44.8)	16.1 (16.1)	31 (7.0)	1.6 (0.5)

+ The Ratings in the table are for R-22 Refrigerant and are calculated at altitude 0 (Sea Level).

+ The Ratings in the table are for 10 Fin Per Inch fin arrangement and aluminum fins.

For other Refrigerants, Altitude, Fin Arrangement and Fin Material, please refer to Correction Factor Tables at the end of this guide.



UNIT RATINGS

Table 3 – Unit Ratings Table

Air Cooled Chiller	Chilled Leaving Water Temp. °F (°C)	Air Temperature Entering Condenser of Chiller (Ambient)																			
		85 °F (29 °C)				95 °F (35 °C)				105 °F (41 °C)				115 °F (46 °C)				125 °F (52 °C)			
		Cooling Capacity Tons (kW)	Comp. Input Power (KW)	Chilled Water GPM (m³/hr)	Chilled Water PD. ft. (m)	Cooling Capacity Tons (kW)	Comp. Input Power (KW)	Chilled Water GPM (m³/hr)	Chilled Water PD. ft. (m)	Cooling Capacity Tons (kW)	Comp. Input Power (KW)	Chilled Water GPM (m³/hr)	Chilled Water PD. ft. (m)	Cooling Capacity Tons (kW)	Comp. Input Power (KW)	Chilled Water GPM (m³/hr)	Chilled Water PD. ft. (m)	Cooling Capacity Tons (kW)	Comp. Input Power (KW)	Chilled Water GPM (m³/hr)	Chilled Water PD. ft. (m)
SLCH 20-2	42 (5.6)	18.6 (65.4)	15.7 (15.7)	45 (10.2)	3.4 (1.0)	17.3 (60.8)	17.0 (17.0)	42 (9.5)	3.0 (0.9)	16.1 (56.5)	18.2 (18.2)	39 (8.9)	2.6 (0.8)	14.8 (52.2)	19.3 (19.3)	36 (8.2)	2.2 (0.7)	13.7 (48.2)	20.3 (20.3)	33 (7.5)	1.9 (0.6)
	44 (6.7)	19.3 (67.9)	15.9 (15.9)	46 (10.4)	3.6 (1.1)	18.0 (63.2)	17.3 (17.3)	43 (9.8)	3.1 (1.0)	16.7 (58.8)	18.5 (18.5)	40 (9.1)	2.7 (0.8)	15.4 (54.3)	19.6 (19.6)	37 (8.4)	2.3 (0.7)	14.2 (50.0)	20.7 (20.7)	34 (7.7)	2.0 (0.6)
	45 (7.2)	19.7 (69.1)	16.0 (16.0)	47 (10.7)	3.8 (1.1)	18.3 (64.5)	17.4 (17.4)	44 (10.0)	3.3 (1.0)	17.0 (59.9)	18.7 (18.7)	41 (9.3)	2.9 (0.9)	15.8 (55.4)	19.8 (19.8)	38 (8.6)	2.5 (0.7)	14.5 (51.0)	20.9 (20.9)	35 (7.9)	2.1 (0.6)
	46 (7.8)	20.1 (70.6)	16.1 (16.1)	48 (10.9)	3.9 (1.2)	18.7 (65.8)	17.5 (17.5)	45 (10.2)	3.4 (1.0)	17.4 (61.1)	18.8 (18.8)	42 (9.5)	3.0 (0.9)	16.1 (56.5)	20.0 (20.0)	39 (8.9)	2.6 (0.8)	14.8 (52.0)	21.1 (21.1)	36 (8.2)	2.2 (0.7)
SLCH 25-1	42 (5.6)	19.2 (67.6)	14.6 (14.6)	46 (10.4)	3.7 (1.1)	18.2 (63.8)	16.1 (16.1)	44 (10.0)	3.4 (1.0)	17.0 (59.8)	17.4 (17.4)	41 (9.3)	2.9 (0.9)	15.9 (56.0)	18.6 (18.6)	38 (8.6)	2.5 (0.8)	14.8 (52.0)	19.8 (19.8)	36 (8.2)	2.2 (0.7)
	44 (6.7)	20.0 (70.2)	14.8 (14.8)	48 (10.9)	4.0 (1.2)	18.9 (66.4)	16.3 (16.3)	45 (10.2)	3.5 (1.1)	17.7 (62.1)	17.7 (17.7)	42 (9.5)	3.1 (0.9)	16.5 (58.1)	18.9 (18.9)	40 (9.1)	2.8 (0.8)	15.4 (54.3)	20.1 (20.1)	37 (8.4)	2.4 (0.7)
	45 (7.2)	20.3 (71.5)	14.9 (14.9)	49 (11.1)	4.2 (1.3)	19.3 (67.7)	16.3 (16.3)	46 (10.4)	3.7 (1.1)	18.0 (63.3)	17.8 (17.8)	43 (9.8)	3.2 (1.0)	16.8 (59.2)	19.1 (19.1)	40 (9.1)	2.8 (0.8)	15.8 (55.4)	20.3 (20.3)	38 (8.6)	2.5 (0.8)
	46 (7.8)	20.8 (73.0)	14.9 (14.9)	50 (11.4)	4.3 (1.3)	19.6 (69.0)	16.4 (16.4)	47 (10.7)	3.8 (1.2)	18.4 (64.6)	17.9 (17.9)	44 (10.0)	3.4 (1.0)	17.2 (60.4)	19.2 (19.2)	41 (9.3)	2.9 (0.9)	16.1 (56.4)	20.5 (20.5)	39 (8.9)	2.6 (0.8)
SLCH 30-1	42 (5.6)	22.5 (79.2)	18.1 (18.1)	54 (12.3)	5.5 (1.7)	21.2 (74.5)	19.7 (19.7)	51 (11.6)	4.9 (1.5)	19.9 (69.8)	21.2 (21.2)	48 (10.9)	4.3 (1.3)	18.5 (65.1)	22.6 (22.6)	44 (10.0)	3.6 (1.1)	17.1 (60.1)	23.9 (23.9)	41 (9.3)	3.1 (1.0)
	44 (6.7)	23.4 (82.3)	18.3 (18.3)	56 (12.7)	5.9 (1.8)	22.0 (77.5)	20.0 (20.0)	53 (12.0)	5.3 (1.6)	20.7 (72.6)	21.5 (21.5)	50 (11.4)	4.7 (1.4)	19.3 (67.7)	23.0 (23.0)	46 (10.4)	4.0 (1.2)	17.8 (62.7)	24.3 (24.3)	43 (9.8)	3.5 (1.1)
	45 (7.2)	23.9 (83.9)	18.5 (18.5)	57 (12.9)	6.1 (1.9)	22.5 (79.0)	20.1 (20.1)	54 (12.3)	5.5 (1.7)	21.1 (74.0)	21.7 (21.7)	51 (11.6)	4.9 (1.5)	19.6 (69.0)	23.2 (23.2)	47 (10.7)	4.1 (1.3)	18.2 (63.9)	24.5 (24.5)	44 (10.0)	3.6 (1.1)
	46 (7.8)	24.3 (85.6)	18.6 (18.6)	58 (13.2)	6.3 (1.9)	22.9 (80.6)	20.3 (20.3)	55 (12.5)	5.7 (1.7)	21.5 (75.5)	21.9 (21.9)	52 (11.8)	5.1 (1.5)	20.0 (70.4)	23.4 (23.4)	48 (10.9)	4.3 (1.3)	18.6 (65.2)	24.7 (24.7)	45 (10.2)	3.8 (1.2)
SLCH 30-2	42 (5.6)	24.7 (86.9)	20.5 (20.5)	59 (13.4)	6.5 (2.0)	23.2 (81.7)	22.4 (22.4)	56 (12.7)	5.9 (1.8)	21.7 (76.3)	24.1 (24.1)	52 (11.8)	5.1 (1.5)	20.2 (71.2)	21.7 (21.7)	49 (11.1)	4.5 (1.4)	18.8 (66.0)	27.2 (27.2)	45 (10.2)	3.8 (1.2)
	44 (6.7)	25.7 (90.4)	20.8 (20.8)	62 (14.1)	7.2 (2.2)	24.1 (84.9)	22.8 (22.8)	58 (13.2)	6.3 (1.9)	22.6 (79.4)	24.5 (24.5)	54 (12.3)	5.5 (1.7)	21.1 (74.1)	18.2 (18.2)	51 (11.6)	4.9 (1.5)	19.5 (68.7)	27.7 (27.7)	47 (10.7)	4.1 (1.3)
	45 (7.2)	26.2 (92.1)	21.0 (21.0)	63 (14.3)	7.4 (2.3)	24.6 (86.4)	23.0 (23.0)	59 (13.4)	6.5 (2.0)	23.0 (81.0)	24.8 (24.8)	55 (12.5)	5.7 (1.7)	21.5 (75.5)	16.4 (16.4)	52 (11.8)	5.1 (1.5)	19.9 (70.1)	28.0 (28.0)	48 (10.9)	4.3 (1.3)
	46 (7.8)	26.7 (94.0)	21.1 (21.1)	64 (14.5)	7.7 (2.3)	25.1 (88.2)	23.1 (23.1)	60 (13.6)	6.7 (2.1)	23.5 (82.7)	25.0 (25.0)	56 (12.7)	5.9 (1.8)	21.9 (77.1)	18.7 (18.7)	53 (12.0)	5.3 (1.6)	20.3 (71.5)	28.3 (28.3)	49 (11.1)	4.5 (1.4)

+ The Ratings in the table are for R-22 Refrigerant and are calculated at altitude 0 (Sea Level).

+ The Ratings in the table are for 10 Fin Per Inch fin arrangement and aluminum fins.

For other Refrigerants, Altitude, Fin Arrangement and Fin Material, please refer to Correction Factor Tables at the end of this guide.



UNIT RATINGS

12

Table 3 – Unit Ratings Table

Air Cooled Chiller	Chilled Leaving Water Temp. °F (°C)	Air Temperature Entering Condenser of Chiller (Ambient)																			
		85 °F (29 °C)				95 °F (35 °C)				105 °F (41 °C)				115 °F (46 °C)				125 °F (52 °C)			
		Cooling Capacity Tons (kW)	Comp. Input Power (KW)	Chilled Water GPM (m³/hr)	Chilled Water PD. ft. (m)	Cooling Capacity Tons (kW)	Comp. Input Power (KW)	Chilled Water GPM (m³/hr)	Chilled Water PD. ft. (m)	Cooling Capacity Tons (kW)	Comp. Input Power (KW)	Chilled Water GPM (m³/hr)	Chilled Water PD. ft. (m)	Cooling Capacity Tons (kW)	Comp. Input Power (KW)	Chilled Water GPM (m³/hr)	Chilled Water PD. ft. (m)	Cooling Capacity Tons (kW)	Comp. Input Power (KW)	Chilled Water GPM (m³/hr)	Chilled Water PD. ft. (m)
SLCH 40-1	42 (5.6)	32.1 (113)	28.2 (28.2)	77 (17.5)	11.1 (3.4)	30.1 (106)	30.6 (30.6)	72 (16.4)	9.7 (3.0)	28.1 (99)	32.9 (32.9)	67 (15.2)	8.4 (2.6)	26.1 (92)	35.0 (35.0)	63 (14.3)	7.4 (2.3)	24.2 (85)	37.0 (37.0)	58 (13.2)	6.3 (1.9)
	44 (6.7)	33.3 (117)	28.6 (28.6)	80 (18.2)	12.0 (3.6)	31.2 (110)	31.1 (31.1)	75 (17.0)	10.5 (3.2)	29.2 (103)	33.5 (33.5)	70 (15.9)	9.2 (2.8)	27.2 (95)	35.7 (35.7)	65 (14.8)	7.9 (2.4)	25.1 (88)	37.8 (37.8)	60 (13.6)	6.7 (2.1)
	45 (7.2)	33.9 (119)	28.8 (28.8)	81 (18.4)	12.3 (3.7)	31.8 (112)	31.3 (31.3)	76 (17.3)	10.8 (3.3)	29.7 (105)	33.8 (33.8)	71 (16.1)	9.4 (2.9)	27.7 (97)	36.0 (36.0)	66 (15.0)	8.1 (2.5)	25.6 (90.0)	38.2 (38.2)	61 (13.9)	7.0 (2.1)
	46 (7.8)	34.6 (122)	29.0 (29.0)	83 (18.9)	12.9 (3.9)	32.5 (114)	31.6 (31.6)	78 (17.7)	11.4 (3.5)	30.3 (107)	34.0 (34.0)	73 (16.6)	10.0 (3.0)	28.2 (99)	36.4 (36.4)	68 (15.4)	8.6 (2.6)	26.1 (92)	38.5 (38.5)	63 (14.3)	7.4 (2.3)
SLCH 40-2	42 (5.6)	30.1 (106)	23.6 (23.6)	72 (16.4)	9.7 (3.0)	28.4 (100)	25.7 (25.7)	68 (15.4)	8.6 (2.6)	26.9 (95)	27.9 (27.9)	65 (14.8)	7.9 (2.4)	24.9 (87)	29.7 (29.7)	60 (13.6)	6.7 (2.1)	23.1 (81)	31.6 (31.6)	56 (12.7)	5.9 (1.8)
	44 (6.7)	31.3 (110)	23.9 (23.9)	75 (17.0)	10.5 (3.2)	29.5 (104)	26.1 (26.1)	71 (16.1)	9.4 (2.9)	27.7 (98)	28.3 (28.3)	67 (15.2)	8.4 (2.6)	25.8 (91)	30.2 (30.2)	62 (14.1)	7.2 (2.2)	24.0 (85)	32.2 (32.2)	58 (13.2)	6.3 (1.9)
	45 (7.2)	31.8 (112)	24.0 (24.0)	76 (17.3)	10.8 (3.3)	30.0 (105)	26.3 (26.3)	72 (16.4)	9.7 (3.0)	28.2 (99)	28.5 (28.5)	68 (15.4)	8.6 (2.6)	26.3 (93)	30.4 (30.4)	63 (14.3)	7.4 (2.3)	24.5 (86)	32.4 (32.4)	59 (13.4)	6.5 (2.0)
	46 (7.8)	32.5 (114)	24.1 (24.1)	78 (17.7)	11.4 (3.5)	30.6 (107)	26.5 (26.5)	73 (16.6)	10.0 (3.0)	28.7 (101)	28.7 (28.7)	69 (15.7)	8.9 (2.7)	26.8 (94)	30.7 (30.7)	64 (14.5)	7.7 (2.3)	25.0 (88)	32.7 (32.7)	60 (13.6)	6.7 (2.1)
SLCH 50-1	42 (5.6)	39.2 (138)	33.1 (33.1)	94 (21.3)	13.3 (4.0)	36.9 (130)	36.0 (36.0)	88 (20.0)	11.6 (3.5)	34.6 (122)	38.8 (38.8)	83 (18.9)	10.3 (3.1)	32.3 (114)	41.5 (41.5)	78 (17.7)	9.1 (2.8)	30.3 (107)	44.1 (44.1)	73 (16.6)	8.0 (2.4)
	44 (6.7)	40.7 (143)	33.5 (33.5)	98 (22.3)	14.4 (4.4)	38.3 (135)	36.5 (36.5)	92 (20.9)	12.7 (3.9)	35.9 (126)	39.4 (39.4)	86 (19.5)	11.1 (3.4)	33.6 (118)	42.2 (42.2)	81 (18.4)	9.8 (3.0)	31.5 (111)	44.9 (44.9)	76 (17.3)	8.7 (2.6)
	45 (7.2)	41.5 (146)	33.7 (33.7)	100 (22.7)	15.0 (4.6)	39.0 (137)	36.8 (36.8)	94 (21.3)	13.3 (4.0)	36.6 (129)	39.7 (39.7)	88 (20.0)	11.6 (3.5)	34.3 (120)	42.6 (42.6)	82 (18.6)	10.1 (3.1)	32.1 (113)	45.3 (45.3)	77 (17.5)	8.9 (2.7)
	46 (7.8)	42.3 (149)	33.8 (33.8)	102 (23.2)	15.6 (4.8)	39.8 (140)	37.0 (37.0)	96 (21.8)	13.8 (4.2)	37.3 (131)	40.0 (40.0)	90 (20.4)	12.2 (3.7)	34.9 (123)	42.9 (42.9)	84 (19.1)	10.6 (3.2)	32.7 (115)	45.7 (45.7)	78 (17.7)	9.1 (2.8)
SLCH 50-2	42 (5.6)	37.6 (132)	30.5 (30.5)	90 (20.4)	12.2 (3.7)	35.4 (124)	33.2 (33.2)	85 (19.3)	10.8 (3.3)	33.2 (117)	35.7 (35.7)	80 (18.2)	9.6 (2.9)	30.9 (109)	38.2 (38.2)	74 (16.8)	8.2 (2.5)	28.9 (101)	40.3 (40.3)	69 (15.7)	7.1 (2.2)
	44 (6.7)	39.0 (137)	30.8 (30.8)	94 (21.3)	13.3 (4.0)	36.7 (129)	33.7 (33.7)	88 (20.0)	11.6 (3.5)	34.6 (122)	36.3 (36.3)	83 (18.9)	10.3 (3.1)	32.2 (113)	38.9 (38.9)	77 (17.5)	8.9 (2.7)	30.0 (105)	41.0 (41.0)	72 (16.4)	7.8 (2.4)
	45 (7.2)	39.8 (140)	31.0 (31.0)	95 (21.6)	13.5 (4.1)	37.4 (131)	34.0 (34.0)	90 (20.4)	12.2 (3.7)	35.2 (124)	36.6 (36.6)	85 (19.3)	10.8 (3.3)	32.8 (115)	39.2 (39.2)	79 (17.9)	9.4 (2.9)	30.6 (107)	41.4 (41.4)	73 (16.6)	8.0 (2.4)
	46 (7.8)	40.5 (143)	31.2 (31.2)	97 (22.0)	14.1 (4.3)	38.1 (134)	34.2 (34.2)	92 (20.9)	12.7 (3.9)	35.9 (126)	36.8 (36.8)	86 (19.5)	11.1 (3.4)	33.4 (117)	39.5 (39.5)	80 (18.2)	9.6 (2.9)	31.2 (110)	41.8 (41.8)	75 (17.0)	8.4 (2.6)

+ The Ratings in the table are for R-22 Refrigerant and are calculated at altitude 0 (Sea Level).

+ The Ratings in the table are for 10 Fin Per Inch fin arrangement and aluminum fins.

For other Refrigerants, Altitude, Fin Arrangement and Fin Material, please refer to Correction Factor Tables at the end of this guide.



UNIT RATINGS

Table 3 – Unit Ratings Table

Air Cooled Chiller	Chilled Leaving Water Temp. °F (°C)	Air Temperature Entering Condenser of Chiller (Ambient)																			
		85 °F (29 °C)				95 °F (35 °C)				105 °F (41 °C)				115 °F (46 °C)				125 °F (52 °C)			
		Cooling Capacity Tons (kW)	Comp. Input Power (KW)	Chilled Water GPM (m³/hr)	Chilled Water PD. ft. (m)	Cooling Capacity Tons (kW)	Comp. Input Power (KW)	Chilled Water GPM (m³/hr)	Chilled Water PD. ft. (m)	Cooling Capacity Tons (kW)	Comp. Input Power (KW)	Chilled Water GPM (m³/hr)	Chilled Water PD. ft. (m)	Cooling Capacity Tons (kW)	Comp. Input Power (KW)	Chilled Water GPM (m³/hr)	Chilled Water PD. ft. (m)	Cooling Capacity Tons (kW)	Comp. Input Power (KW)	Chilled Water GPM (m³/hr)	Chilled Water PD. ft. (m)
SLCH 60-1	42 (5.6)	46.9 (165)	39.8 (39.8)	113 (25.7)	18.2 (5.6)	44.0 (155)	43.3 (43.3)	106 (24.1)	16.0 (4.9)	41.4 (145)	46.4 (46.4)	99 (22.5)	14.0 (4.3)	38.7 (136)	49.6 (49.6)	93 (21.1)	12.3 (3.8)	36.2 (127)	52.7 (52.7)	87 (19.8)	10.8 (3.3)
	44 (6.7)	48.7 (171)	40.4 (40.4)	117 (26.6)	6.0 (6.0)	45.7 (161)	43.9 (43.9)	110 (25.0)	5.3 (5.3)	43.0 (151)	47.2 (47.2)	103 (23.4)	4.6 (4.6)	40.2 (141)	50.5 (50.5)	97 (22.0)	4.1 (4.1)	37.7 (133)	53.7 (53.7)	90 (20.4)	11.6 (3.5)
	45 (7.2)	49.6 (174)	40.7 (40.7)	119 (27.0)	6.2 (6.2)	46.6 (164)	44.2 (44.2)	112 (25.4)	5.5 (5.5)	43.8 (154)	47.6 (47.6)	105 (23.8)	4.8 (4.8)	41.0 (144)	50.9 (50.9)	98 (22.3)	4.2 (4.2)	38.4 (135)	54.2 (54.2)	92 (20.9)	12.1 (3.7)
	46 (7.8)	50.6 (178)	40.9 (40.9)	122 (27.7)	6.5 (6.5)	47.6 (167)	44.5 (44.5)	114 (25.9)	5.7 (5.7)	44.6 (157)	47.9 (47.9)	107 (24.3)	5.0 (5.0)	41.8 (147)	51.3 (51.3)	101 (22.9)	4.4 (4.4)	39.2 (138)	54.7 (54.7)	94 (21.3)	12.6 (3.8)
SLCH 60-2	42 (5.6)	44.5 (156)	29.4 (29.4)	107 (24.3)	5.0 (5.0)	41.8 (147)	40.1 (40.1)	100 (22.7)	4.3 (4.3)	39.1 (138)	43.0 (43.0)	94 (21.3)	3.8 (3.8)	36.4 (128)	45.7 (45.7)	87 (19.8)	3.3 (3.3)	33.7 (118)	48.1 (48.1)	81 (18.4)	9.4 (2.9)
	44 (6.7)	46.2 (163)	22.3 (22.3)	111 (25.2)	5.4 (5.4)	43.5 (153)	40.7 (40.7)	104 (23.6)	4.7 (4.7)	40.7 (143)	43.7 (43.7)	98 (22.3)	4.2 (4.2)	37.9 (133)	46.5 (46.5)	91 (20.7)	3.6 (3.6)	35.1 (123)	49.1 (49.1)	84 (19.1)	10.1 (3.1)
	45 (7.2)	47.1 (166)	18.8 (18.8)	113 (25.7)	5.6 (5.6)	44.3 (156)	41.0 (41.0)	106 (24.1)	4.9 (4.9)	41.5 (146)	44.0 (44.0)	100 (22.7)	4.3 (4.3)	38.6 (136)	46.9 (46.9)	93 (21.1)	3.8 (3.8)	35.8 (126)	49.5 (49.5)	86 (19.5)	10.6 (3.2)
	46 (7.8)	48.0 (169)	22.8 (22.8)	116 (26.3)	5.9 (5.9)	45.2 (159)	41.3 (41.3)	109 (24.8)	5.2 (5.2)	42.3 (149)	44.4 (44.4)	102 (23.2)	4.5 (4.5)	39.4 (139)	47.3 (47.3)	95 (21.6)	3.9 (3.9)	36.5 (128)	50.0 (50.0)	88 (20.0)	11.1 (3.4)
SLCH 80-2	42 (5.6)	65.0 (229)	55.2 (55.2)	156 (35.4)	6.7 (6.7)	61.2 (215)	59.9 (59.9)	147 (33.4)	5.9 (5.9)	57.1 (201)	64.7 (64.7)	137 (31.1)	5.1 (5.1)	53.2 (187)	69.0 (69.0)	128 (29.1)	4.5 (4.5)	49.2 (173)	73.1 (73.1)	118 (26.8)	12.5 (3.8)
	44 (6.7)	67.6 (238)	55.8 (55.8)	162 (36.8)	7.2 (7.2)	63.6 (223)	60.9 (60.9)	153 (34.7)	6.4 (6.4)	59.4 (209)	65.8 (65.8)	143 (32.5)	5.6 (5.6)	55.3 (195)	70.3 (70.3)	133 (30.2)	4.9 (4.9)	51.2 (180)	74.5 (74.5)	123 (27.9)	13.6 (4.1)
	45 (7.2)	68.9 (242)	56.2 (56.2)	166 (37.7)	7.6 (7.6)	64.7 (228)	61.4 (61.4)	156 (35.4)	6.7 (6.7)	60.6 (213)	66.3 (66.3)	146 (33.2)	5.8 (5.8)	56.4 (198)	70.9 (70.9)	136 (30.9)	5.1 (5.1)	52.3 (184)	75.2 (75.2)	126 (28.6)	14.3 (4.4)
	46 (7.8)	70.3 (247)	56.5 (56.5)	169 (38.4)	7.8 (7.8)	66.0 (232)	61.8 (61.8)	159 (36.1)	6.9 (6.9)	61.8 (217)	66.8 (66.8)	149 (33.8)	6.1 (6.1)	57.6 (202)	71.5 (71.5)	139 (31.6)	5.3 (5.3)	53.3 (188)	75.9 (75.9)	128 (29.1)	14.7 (4.5)
SLCH 100-2	42 (5.6)	78.0 (274)	66.1 (66.1)	187 (42.5)	7.3 (7.3)	73.3 (258)	72.5 (72.5)	176 (40.0)	6.5 (6.5)	68.7 (242)	78.0 (78.0)	165 (37.5)	5.7 (5.7)	64.4 (226)	83.4 (83.4)	155 (35.2)	5.0 (5.0)	60.3 (212)	88.6 (88.6)	145 (32.9)	14.4 (4.4)
	44 (6.7)	81.1 (285)	67.2 (67.2)	195 (44.3)	7.9 (7.9)	76.2 (268)	73.4 (73.4)	183 (41.6)	7.0 (7.0)	71.5 (251)	79.2 (79.2)	172 (39.1)	6.2 (6.2)	67.0 (236)	84.7 (84.7)	161 (36.6)	5.4 (5.4)	—	—	—	—
	45 (7.2)	82.7 (291)	67.7 (67.7)	199 (45.2)	8.2 (8.2)	77.7 (273)	73.9 (73.9)	187 (42.5)	7.3 (7.3)	72.9 (256)	79.8 (79.8)	175 (39.7)	6.4 (6.4)	68.3 (240)	85.4 (85.4)	164 (37.2)	5.6 (5.6)	—	—	—	—
	46 (7.8)	84.3 (296)	68.1 (68.1)	202 (45.9)	8.5 (8.5)	79.2 (279)	74.4 (74.4)	190 (43.2)	7.5 (7.5)	74.3 (261)	80.4 (80.4)	178 (40.4)	6.6 (6.6)	69.6 (245)	86.1 (86.1)	167 (37.9)	5.8 (5.8)	—	—	—	—

+ The Ratings in the table are for R-22 Refrigerant and are calculated at altitude 0 (Sea Level).

+ The Ratings in the table are for 10 Fin Per Inch fin arrangement and aluminum fins.

For other Refrigerants, Altitude, Fin Arrangement and Fin Material, please refer to Correction Factor Tables at the end of this guide.

CORRECTION FACTORS

+ **U**se these correction factors as multipliers to the capacity ratings offered in the tables.

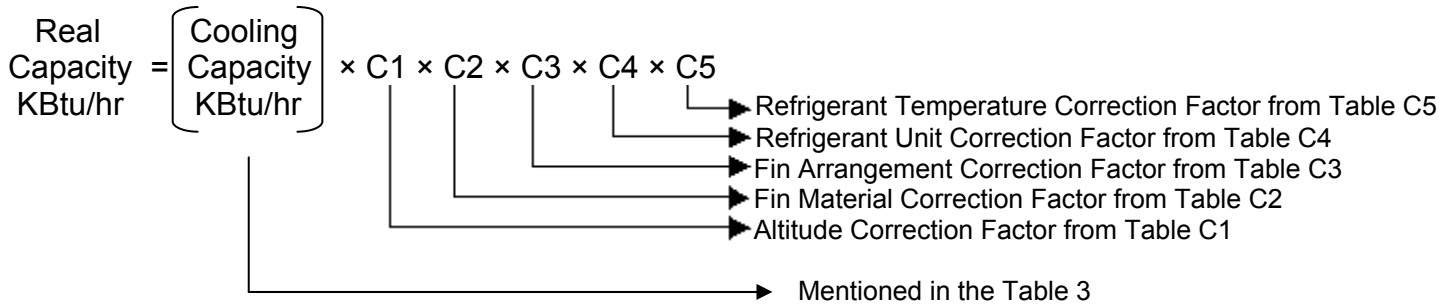

Or

+ **D**ivide your required capacity by these correction factors before you go through the tables.

1. Altitude Correction Factor (C1)

The capacity ratings in the tables are calculated for sea level (alt=0). For installing units in any different altitudes use these Correction factors.

Altitude		Correction Factor
(ft)	(m)	
0	0	1.00
2500	760	0.98
5000	1500	0.97
7500	2300	0.95
10000	3050	0.93

Table C1- Altitude Correction Factor (C1)

2. Fin Material Correction Factor (C2)

Fins of condenser coil can be of different materials. The ratings in the table are offered for Aluminum fin type. Use the related correction factor for Copper (Cu) fins.

Fin Material	Correction Factor
Al	1
Cu	1.01

Table C2 - Fin Material Correction Factor (C2)

3. Fin Arrangement Correction Factor (C3)

Tubes of coils can have any different number of fins along one inch of their length. The ratings in tables are for 10 fins per inch. For other desired fin arrangement use these correction factors.

Coil Fin Per Inch	Correction Factor
8	0.993
10	1
12	1.006
14	1.011
16	1.015

Table C3 - Fin Arrangement Correction Factor (C3)

4. Refrigerant Correction Factor (C4 & C5)

The ratings in the tables are for refrigerant R-22. **If it is desired to use other refrigerants than R-22** in the units, these correction factors should be applied. (i.e. for R-22, C4 and C5 are 1.)



Different Units Correction Factor (C4)

The effect of replacing R-134a or R-407c with R-22 would result in changing compressor and this has a different impact on every unit. Use specified factor for every unit type.

In cases you are about to select the unit and do not have any idea about unit type, use your intuition! One try and error can lead you to choose the correct unit.

R-134a		R-407c	
Unit Type	Correction Factor	Unit Type	Correction Factor
10-1	1.082	10-1	1.107
15-1	0.988	15-1	1.084
15-2	0.884	15-2	0.975
20-1	0.985	20-1	0.991
20-2	1.083	20-2	1.100
25-1	0.942	25-1	0.991
30-1	0.961	30-1	0.991
30-2	0.988	30-2	1.069
40-1	0.807	40-1	0.989
40-2	0.984	40-2	1.003
50-1	0.775	50-1	1.008
50-2	0.943	50-2	1.008
60-1	0.761	60-1	1.003
60-2	0.962	60-2	0.949
80-2	0.807	80-2	0.982
100-2	0.774	100-2	1.003

Working Point Temperature Correction Factor (C5)

By defining desired unit working point (even by guessing) it is possible to estimate R-134a and R407C behavior in different temperatures.

Temperature Correction Factor (C5)			Air Temperature Entering Condenser (Ambient) (°F)				
			85	95	105	115	125
R-134a	(Leaving Water Temp. °F)	42	0.997	0.982	0.971	0.967	0.953
		44	1.000	0.988	0.975	0.971	0.958
		45	1.002	0.991	0.978	0.973	0.960
		46	1.003	0.992	0.980	0.975	0.963
R-407C	(Leaving Water Temp. °F)	42	1.009	0.994	0.972	0.960	0.940
		44	1.010	0.995	0.975	0.963	0.944
		45	1.011	0.995	0.976	0.964	0.946
		46	1.012	0.996	0.977	0.966	0.948

Table C4 - R-134a Different Units Correction Factor (C4)

Table C5 - R-134a and R-407C Working Point Temperature Correction Factor (C5)

SOUND RATINGS

Unit sound ratings are measured while full load working condition (Compressor(s) and fans are all running). So the sound power levels are for compressor(s) and fans together (Table S-1).

Total Sound Power Level (Compressor(s) + Fans) (dB)																
Unit Type SLCH-A	10-1	15-1	15-2	20-1	20-2	25-1	30-1	30-2	40-1	40-2	50-1	50-2	60-1	60-2	80-2	100-2
Sound Level (dB)	83	84	83	87	87	87	91	88	91	88	90	89	90	93	93	93

Table S-1. Total Sound Power Level (Compressor(s) + Fans) (dB)



PRESSURE DROP CURVES

Use these curves in order to estimate the correct pressure drop in different flow rates of chilled water passing through evaporator of the chiller.

Attention: The amounts of GPM specified in the "Unit Ratings Table" are the design point GPMs. It means that if it is desired to have the leaving water temperature mentioned in the table, it is necessary to have exactly the specified GPM of water in passing through evaporator of chiller.

Figure 1 - Chilled Water Pressure Drop Curves

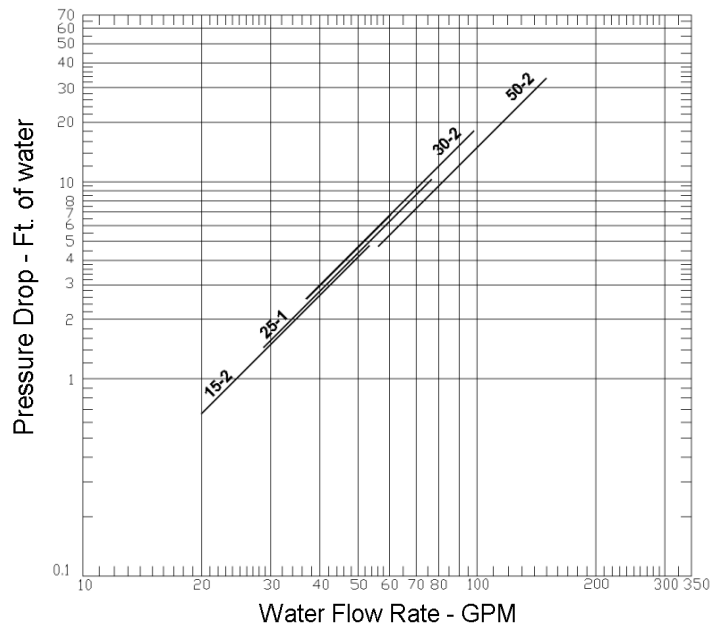
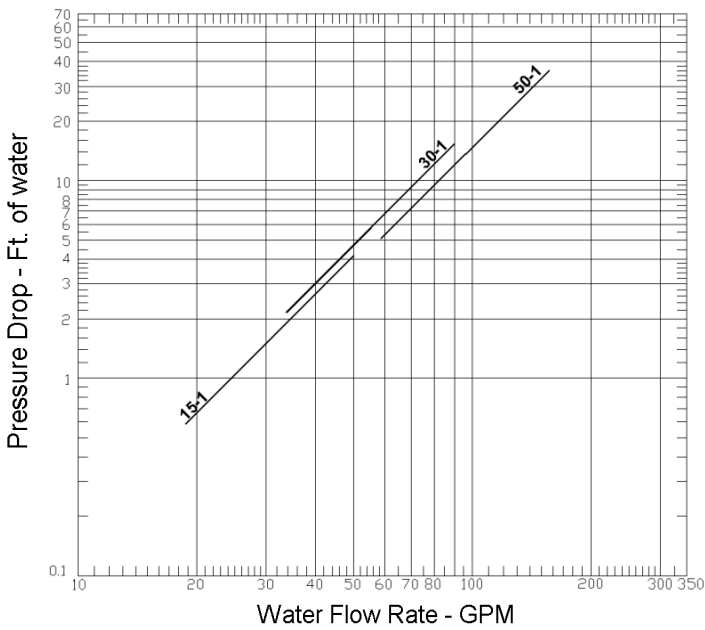
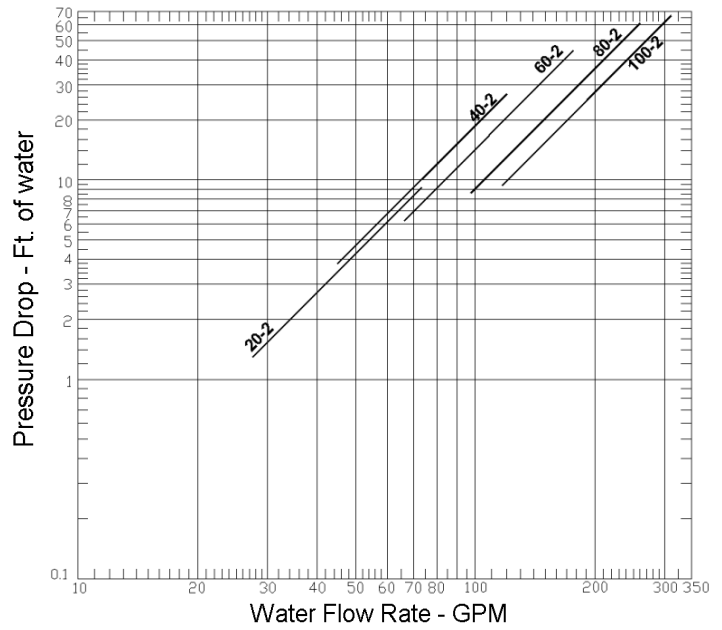
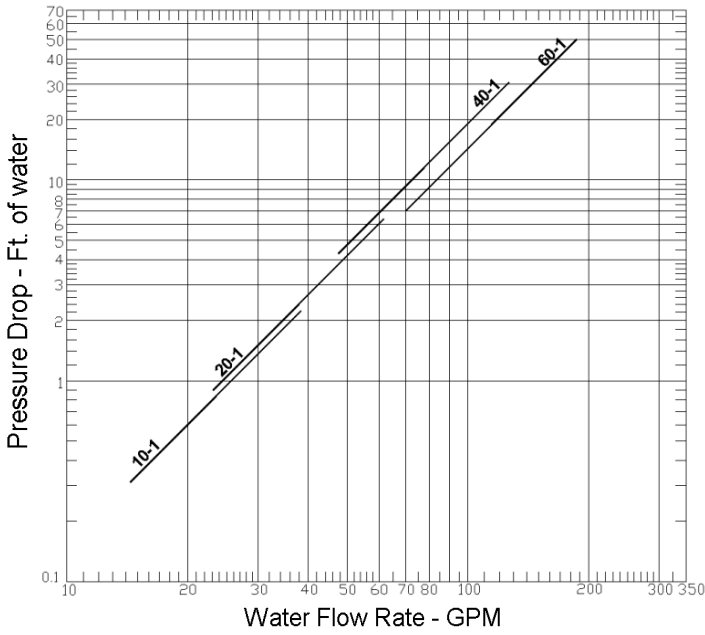

DIMENSIONS

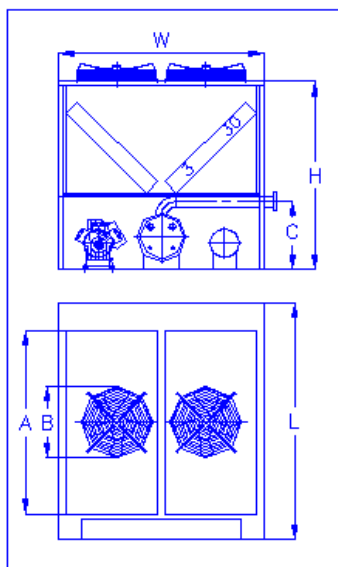

SLCH-A 10-1 15-1 15-2

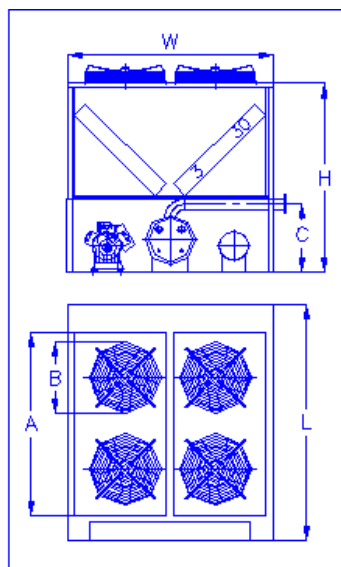

SLCH-A 20-1 20-2

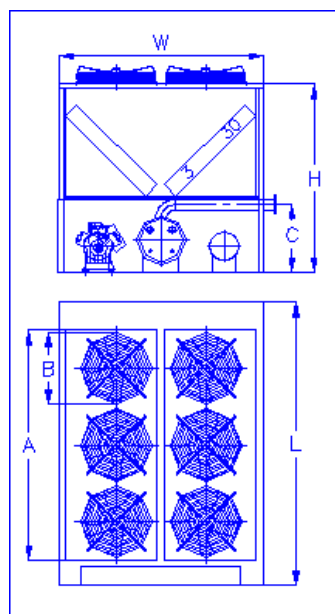

SLCH-A 25-1 30-1 30-2
40-1 40-2

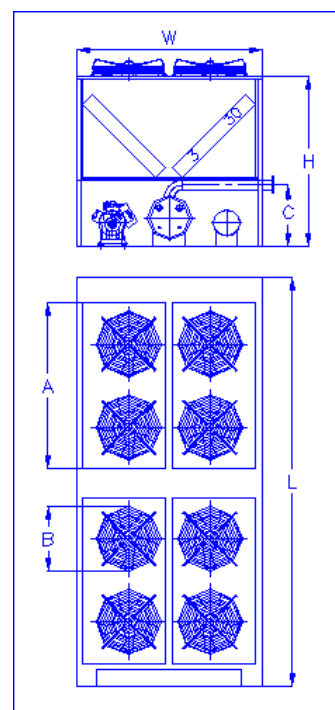

SLCH-A 50-1 50-2
60-1 60-2

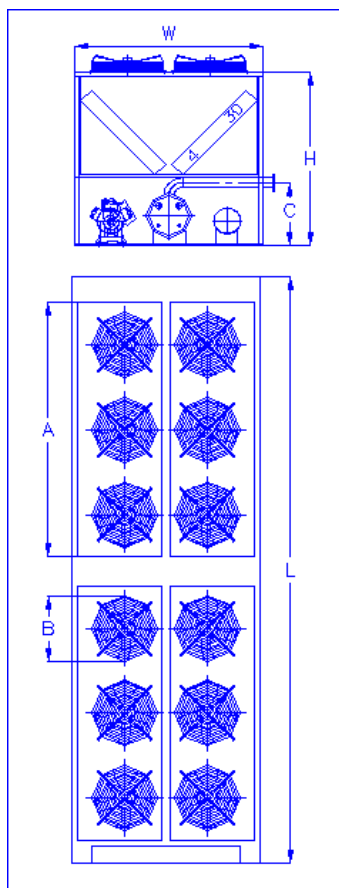

SLCH-A 80-2 100-2

Model	Used Condenser Model	L (Length) mm	W (Width) mm	H (Height) mm	A (Coil Length) mm	B (Fan Diam.) mm	C (Conn. Height) mm
SLCH-A 10-1	SAC-250	2500	2170	2000	1940	756	722
SLCH-A 15-1	SAC-250	2500	2170	2000	1940	756	722
SLCH-A 15-2	SAC-250	2500	2170	2000	1940	756	722
SLCH-A 20-1	SAC-350	2500	2170	2000	1940	756	722
SLCH-A 20-2	SAC-350	2500	2170	2000	1940	756	722
SLCH-A 25-1	SAC-450	3000	2170	2000	2440	756	722
SLCH-A 30-1	SAC-450	3000	2170	2000	2440	756	722
SLCH-A 30-2	SAC-450	3000	2170	2000	2440	756	722
SLCH-A 40-1	SAC-550	3500	2170	2000	2940	756	722
SLCH-A 40-2	SAC-550	3500	2170	2000	2940	756	722
SLCH-A 50-1	SAC-700	4780	2170	2000	1940	756	722
SLCH-A 50-2	SAC-700	4780	2170	2000	1940	756	722
SLCH-A 60-1	SAC-850	5780	2170	2000	2440	756	722
SLCH-A 60-2	SAC-850	5780	2170	2000	2440	756	722
SLCH-A 80-2	SAC-1200	6780	2170	2000	2940	756	722
SLCH-A 100-2	SAC-1200	6780	2170	2000	2940	756	722

SPACE AND LOCATION REQUIREMENTS

The most important consideration when selecting the location of air cooled liquid chiller, is the provision for a supply of ambient air to the condenser, and removal of the heated air from the condenser coils for this purpose SARAVEL recommends the minimum space requirements illustrated below. Failure to adhere to these requirements will result in higher condensing temperature, which can cause unsafe operation of the condenser and the possible

failure of the compressor. Units must not be located in the vicinity of steam, hot air or fume exhausts. Another important consideration is that the unit should be mounted away from noise sensitive spaces and must have adequate support to prevent vibration and noise transmission into the building. Units can be installed over corridors, utility areas, rest rooms and other auxiliary areas where high levels of sound are not an important factor.

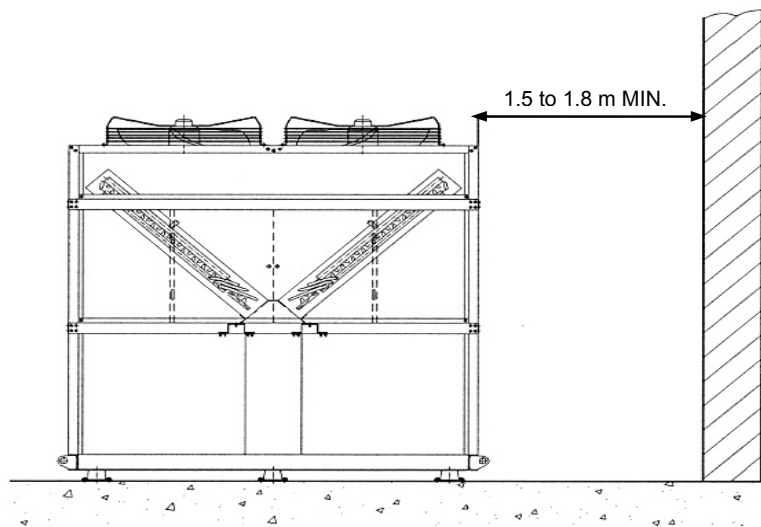

WALLS OR OBSTRUCTIONS

Units should be located so that air may circulate freely and not be reticulated. For proper air flow and access all sides of the units must be a minimum of 1.5 meters away from any wall or obstructions.

It is preferred that this distance be longer whenever possible. Sufficient room should be left for maintenance work through access doors and panels. Overhead obstructions are not permitted.

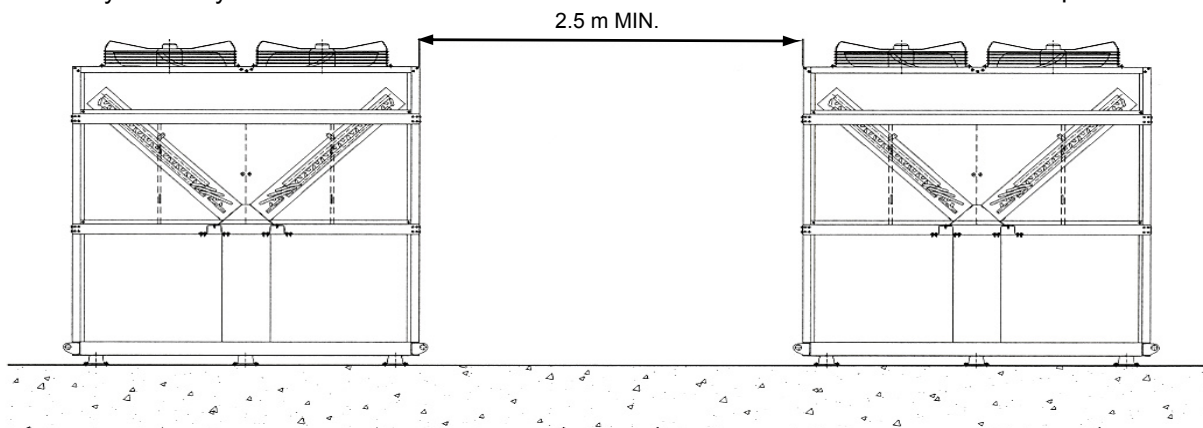

MULTIPLE UNITS

For units placed side by side, the minimum distance between units is 2.5 m. If units are placed end to end, the minimum distance between units is 2.5 meters.

INSTALLATION RECOMMENDATIONS

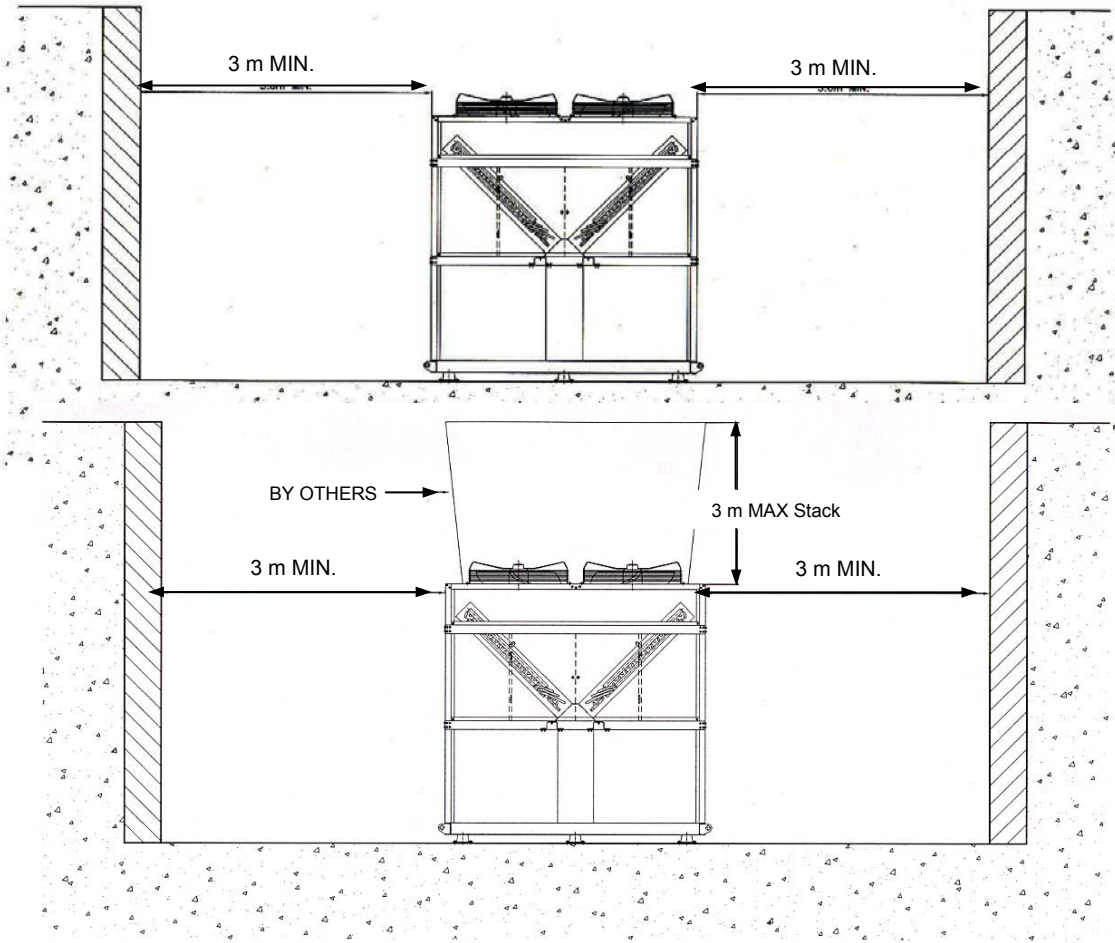

UNITS IN PITS

The top of the unit should be level with the top of the pit, and side distance increased to 3 meter. If the top of the unit is not level with the top of the pit discharge

cones or stacks must be used to raise discharge air to the top of the pit.

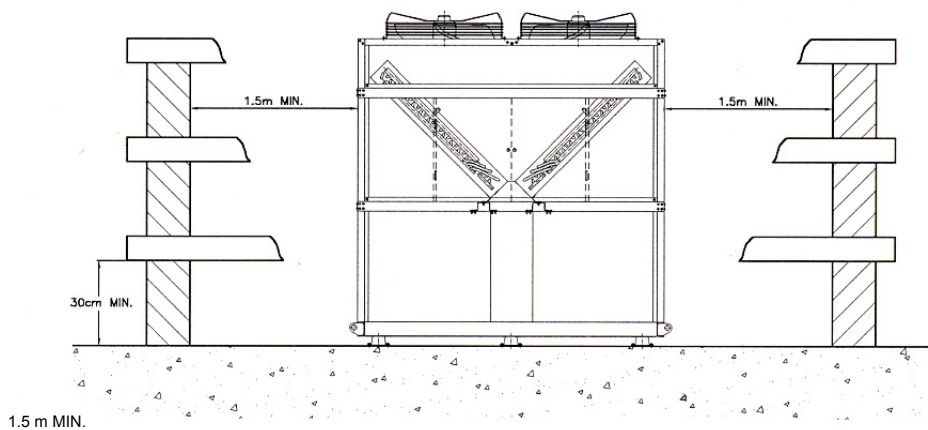

FENCES

Fences must have 50% free area, with a 30cm under cut and 1.5m minimum clearance and it must not exceed the top of units.



SARAVEL CORP.
Nov. 2003

Manufacturer reserves the right to make changes in design and construction, without notice.

(Head Office)

No. 43, North Sheikh Bahai Avenue, Tehran 19917 , IRAN

Tel: (+98-21) 88046921 (6 lines) Fax: (+98-21) 88046920

E-Mail: sales@saravel.com

Site: <http://www.Saravel.com>